

CO-10 mass flow meter

Technical data

The mass flow meter type **CO-10** offers a high precision measurement device for bulk solids combined with easy installation procedure in existing material flows.

- Industrial design with a minimum of moving parts, ensure maximum reliability with easy maintenance.
- Designed for easy installation with lowest distance between inlet and outlet flanges.
- Only cables for mains power and transducer/tachometer connection required to instrumentation.
- Optional stainless-steel design and turbines for abrasive materials available.

Advanced flow controller with functions such as: Flow indication and Totalising. Optional controller with PID regulation and batch-out functions available.



Capacity

Capacity	Min 500 kg/h Max 10 t/h ~ 20 m ³ /h
Bulk density	Min. 0,3 t/m ³
Product size	Max 10 mm
Material temperature	Max 100 °C

* Limits are for guidance and depend on material specifications.

Technical data

Ambient temp.	0-40 °C
Material inlet/outlet	250/350 mm
Accuracy	0,5-1,0 % (depending on capacity and/or material.)
Repeatability	0,1 %
Drive	3-phase 220/400 V, 0,75kW, IP54
Load sensor	S-E-G Torque transducer type ON4-, IP67

Additional

Motor Control	By frequency controller
Design	Standard Blue industrial coating Optional Stainless steel SIS 2333 (AISI 304)
Weight	Aprox. 120 kg

Dimensions

All dimensions are in mm.

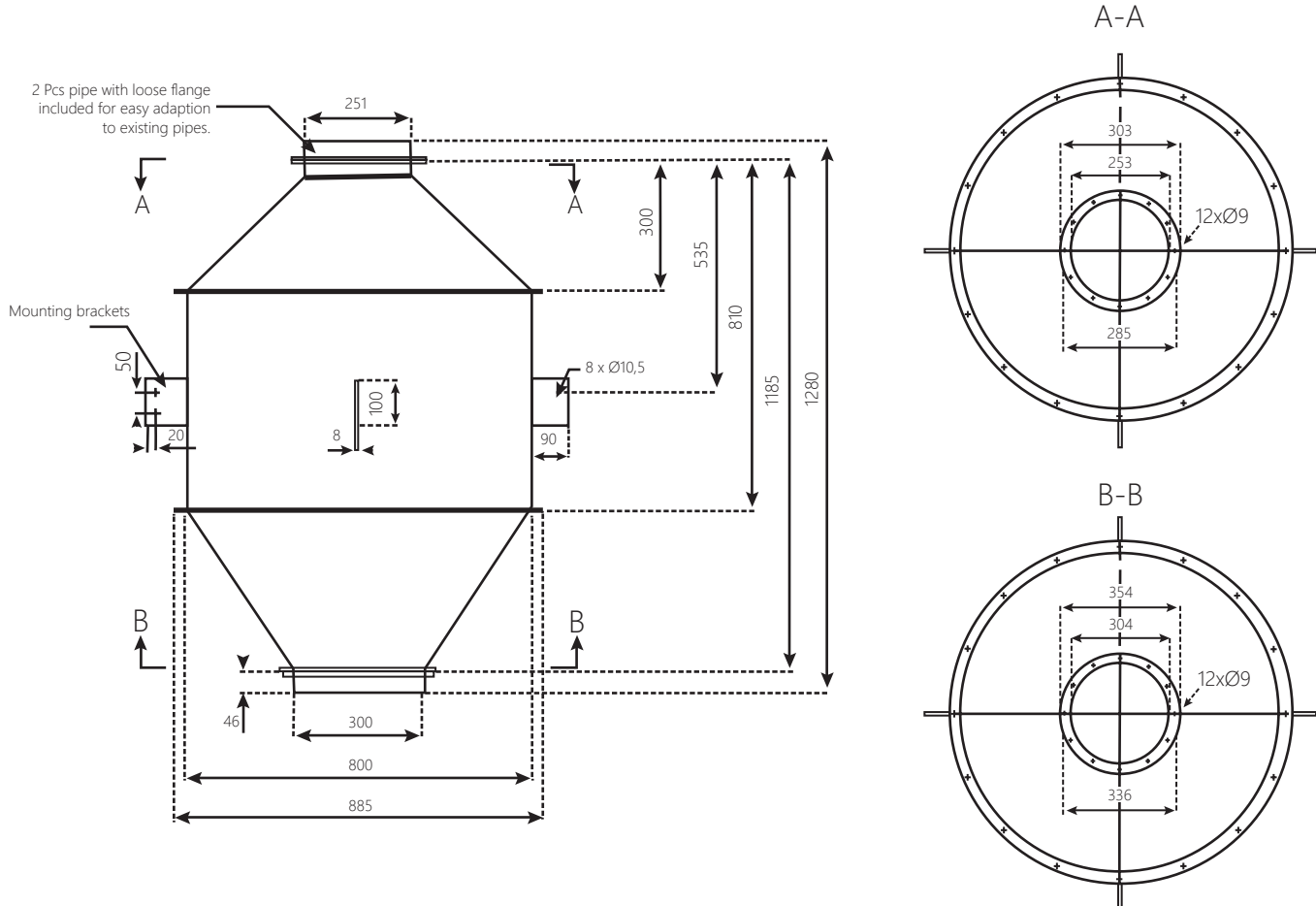

Designations

Flow meter	CO-10B
Load sensors	ON4-7
Frequency controller	CON-075
Controller	Model T3650 (Spec. T42-650E) Model A2-F12 (Spec. F44-F12E)

Options

- Turbine for abrasive materials
- High temperature version
- Design in Stainless Steel SIS2333 (AISI304)
- By-pass tube