

Weigh feeders

Reliable accuracy



Advanced weighing and dosing systems for static, dynamic, and continuous weighing.

jesma[®]
weighing solutions







Weigh feeders

Overview: Weigh feeders

Focusing on optimum reliability, long lifetime, and high accuracy. With a weigh feeder from Jesma you gain the following advantages.

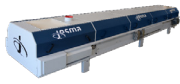
An incremental encoder (tacho) is mounted on the idle roller which improves continuous monitoring of the belt and ensures immediate alarm signal on belt drive irregularities.

Over dimensioned load cells securing high accuracy even with an uneven material flow. A crown driving roller facilitates tracking of the belt during operation and reduces the risk of belt slide.

				
	JesBelt® A	JesBelt® S	JesBelt® D	JesBelt® F
Typical applications	Coarse, granular, dustlike bulk materials, meal, grains and wood chips etc.	Coarse, granular, dustlike bulk materials such as corn, meal, sand etc.	Coarse, granular, dustlike bulk materials, for example different types of meal.	Coarse, granular, dustlike bulk materials with high temperature and/or abrasive characteristics.
Approval	Class 0,5, 1, and 2 OIML R50 Welmecc and MID			
Accuracy from	±0.25%	± 1%	±1 %	±1 %
Capacity range	0.2 - 1000 m ³ /h	0.2 - 1000 m ³ /h	40 - 125 m ³ /h	0.5 - 1000 m ³ /h
Product temperature	-30°...+110°/130°	-30°...+110°/130°	-30°...+110°/110°	-30°...+160°/200°
ATEX options	Zone 21+22	Zone 21+22	Zone 21+22	Zone 21+22
Belt width	500-1600 mm	500-1600 mm	360-610 mm	300-1200 mm
Construction	Mild steel or AISI 304 Open or with dust cover	Mild steel or AISI 304 Open or with dust cover	Mild steel or AISI 304 Open or with dust cover	Mild steel or AISI 304 Open or with dust cover

JesBelt® A

Very high accuracy - optimal reliability

The reliable and accurate JesBelt A is the result of many years of experience. Based on several hundreds of supplied JesBelt A, the A solution represents the optimum technical solution within weigh feeders.

The design is highly flexible, has long lifetime and is suitable for a wide range of process industries where high accuracy and linearity form the basis of an efficient product line.

Description of the JesBelt A

The JesBelt A is designed and constructed for continuous weighing of a material transported on a belt, or for regulation of a specific material flow. The weigh feeder is built around an isolated weigh bridge with 4 pcs load cells.

To perform with the best possible weighing/feeding accuracy and linearity the JesBelt A is equipped with a high pulse frequency speed sensor. The speed is continuously monitored via an incremental encoder: a tacho, that in turn alarms the operator by the slightest irregularities in the operation of the weigh feeder.

The conveyor belt is fitted with plough shaped scraper on the inside of the belt. The scraper ensures that any adhesive material is removed from the belt thus not influencing the weighing accuracy.

The JesBelt A is available in a range of standard sizes in coated steel, stainless steel AISI304, or a combination of the two with product wetted part in Stainless steel. Beside the wide standard range the JesBelt A is also available as project designed equipment specified to the customer's requirements.

JesBelt A in general

- Approvable according to OIML R50, Welmec and MID for purchase and sales. Class 0,5, 1, and 2.
- Accuracy from 0,25 % (subject to final design and product characteristics).
- Max capacity: 1000 m³/h.
- Ambient temperature for approved versions: -10 °C ... +40 °C.



Options for individual design of JesBelt A

- Flexible rim to eliminate product spill.
- Dust cover including connection with flanged inlet and outlet for dust extraction.
- Dust tray for manual emptying.
- Dust tray with automatic scraper bottom.
- Scrapers for adhesive and sticky products.
- Inlet funnel with damper for regulation of product flow.
- Outlet funnel.
- Belt tracking switches.
- Automatic belt alignment JesTrack.
- Emergency stop with wire.
- ATEX compliant components.
- JesBelt A-HD for heavy-duty applications.
- JesBelt A-FG and JesBelt A-FG Flex for the wet, hygienic and food industries.

Standard range: JesBelt® A

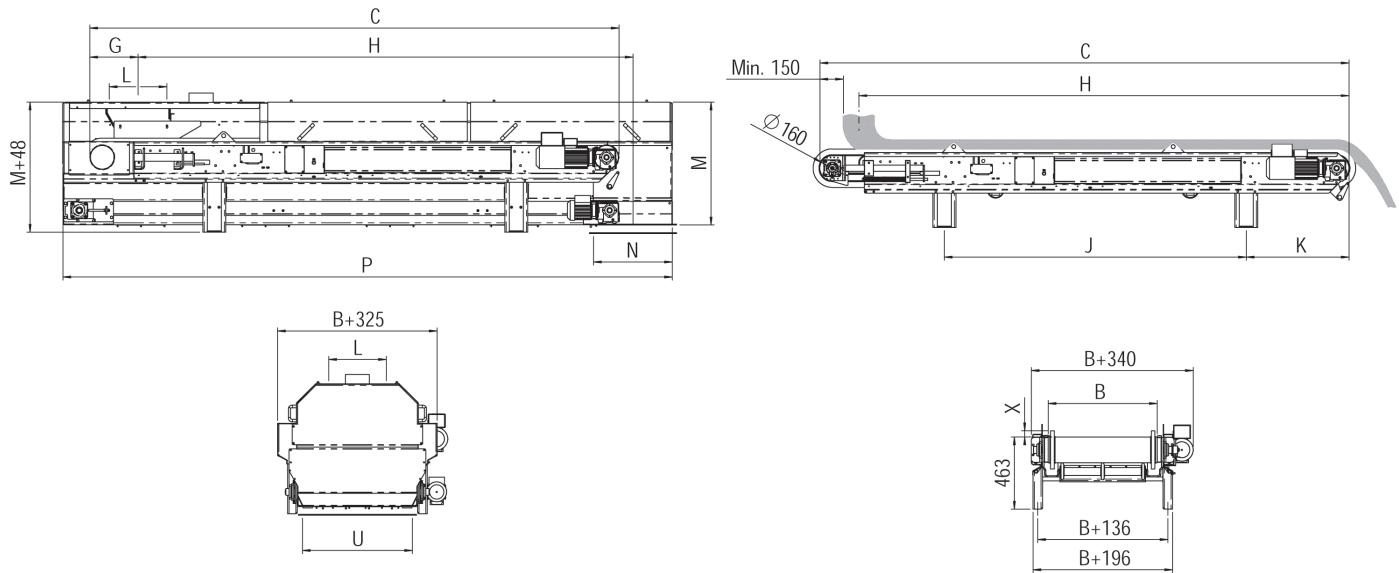

JesBelt A 500 [up to 60 m³/h]

C	B	J	K	H*	G	L	U*	M*	N*	P	X**	Weight open	Weight closed
2200	500	1140	450	2030/2050	160	200	466/506	610/790	466/506	2715	20-100	280 kg	650 kg
2800	500	1540	550	2630/2650	160	200	466/506	610/790	466/506	3315	20-100	295 kg	700 kg
3400	500	1940	650	3230/3250	160	200	466/506	610/790	466/506	3915	20-100	310 kg	750 kg
4200	500	2740	650	4030/4050	160	200	466/506	610/790	466/506	4715	20-100	330 kg	820 kg

JesBelt A 700 [up to 120 m³/h]

2800	700	1540	550	2580/2600	210	300	666/706	610/790	466/506	3315	20-100	325 kg	870 kg
3400	700	1940	650	3180/3200	210	300	666/706	610/790	466/506	3915	20-100	340 kg	920 kg
4200	700	2740	650	3980/4000	210	300	666/706	610/790	466/506	4715	20-100	360 kg	990 kg

JesBelt A 900 [up to 250 m³/h]

2800	900	1540	600	2530/2550	310	500	866/906	700/880	566/606	3415	20-100	355 kg	1040 kg
3400	900	1940	700	3130/3150	310	500	866/906	700/880	566/606	4015	20-100	370 kg	1090 kg
4200	900	2740	700	3930/3950	310	500	866/906	700/880	566/606	4815	20-100	390 kg	1160 kg

JesBelt A 1100 [up to 400 m³/h]

3400	1100	1940	700	3030/3050	410	700	1066/1106	700/880	566/606	4015	20-100	400 kg	1260 kg
4200	1100	2740	700	3830/3850	410	700	1066/1106	770/880	566/606	4815	20-100	420 kg	1330 kg
4800	1100	3140	700	4230/4250	410	700	1066/1106	770/880	566/606	5215	20-100	440 kg	1400 kg

X = flexible rim or guide rails * Standard length or with manual dust tray / length with emptying conveyor ** Depending on belt type

Available in: Standard range with belt width 500 | 700 | 900 | 1100 | Project designed equipment | **Special versions:** JesBelt A-HD (Heavy-duty applications), JesBelt A-FG and JesBelt A-FG Flex | **Contact Jesma for more information**

JesBelt® S

Versatile with optimum lifetime and reliability

The reliable and accurate JesBelt S provides a competitive alternative to the JesBelt A in weighing processes where no trade approval is required.

The JesBelt S is designed to provide excellent reliability and has a long product lifetime. The flexible design makes it suitable for a wide range of process industries where the production calls for high accuracy and linearity.

Description of the JesBelt S

The weighing section in the JesBelt S is inserted in the construction as a roller mounted on 2 pcs load cells. The construction provides excellent stability and accuracy, and together with the high signal rate incremental encoder (Tacho), a perfect operation and reliability in the daily use is achieved.

The tacho is mounted on the idle drum of the conveyor, continuously monitoring the speed of the belt and alarming the operator if any irregularities occur during operation of the weigh feeder.

The conveyor belt is fitted with plough shaped scraper on the inside of the belt. The scraper ensure that any adhesive material is removed from the belt thus not influencing the weighing accuracy.

The JesBelt S is available in a range of standard sizes in coated steel, stainless steel AISI304, or a combination of the two with product wetted part in Stainless steel. Beside the wide standard range the JesBelt S is also available as project designed equipment specified to the customer's requirements.

JesBelt S in general

- Accuracy from 1 % (subject to final design and product characteristics).
- Max capacity: 1000 m³/h.



Options for individual design of JesBelt S

- Flexible rim to eliminate product spill.
- Dust cover including connection with flanged inlet and outlet for dust extraction.
- Dust tray for manual emptying.
- Dust tray with automatic scraper bottom.
- Scrapers for adhesive and sticky products.
- Inlet funnel with damper for regulation of product flow.
- Outlet funnel.
- Belt tracking switches.
- Emergency stop with wire.
- ATEX compliant components.
- Automatic belt alignment JesTrack.
- Emergency stop with wire.
- ATEX compliant components.

Standard range: JesBelt® S

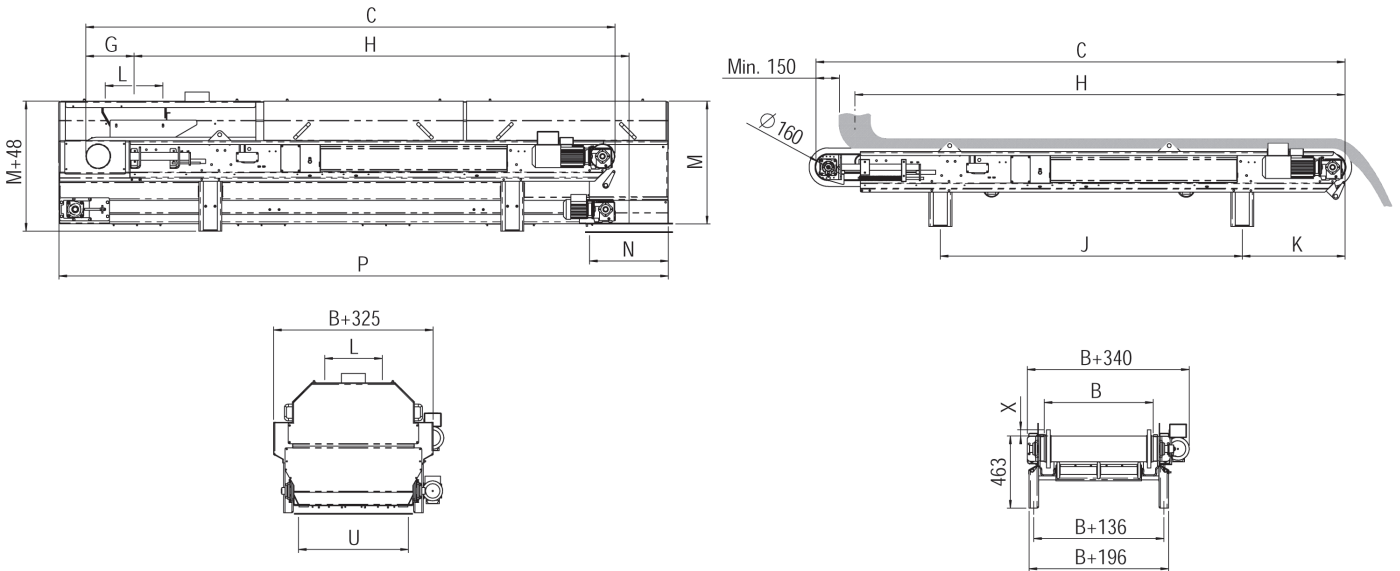

JesBelt S 500 [up to 60 m ³ /h]												Weight open	Weight closed
C	B	J	K	H*	G	L	U*	M*	N*	P	X**		
2200	500	1140	450	2030/2050	160	200	466/506	610/790	466/506	2715	20-100	280 kg	650 kg
2800	500	1540	550	2630/2650	160	200	466/506	610/790	466/506	3315	20-100	295 kg	700 kg
3400	500	1940	650	3230/3250	160	200	466/506	610/790	466/506	3915	20-100	310 kg	750 kg
4200	500	2740	650	4030/4050	160	200	466/506	610/790	466/506	4715	20-100	330 kg	820 kg

JesBelt S 700 [up to 120 m ³ /h]												Weight open	Weight closed
C	B	J	K	H*	G	L	U*	M*	N*	P	X**		
2800	700	1540	550	2580/2600	210	300	666/706	610/790	466/506	3315	20-100	325 kg	870 kg
3400	700	1940	650	3180/3200	210	300	666/706	610/790	466/506	3915	20-100	340 kg	920 kg
4200	700	2740	650	3980/4000	210	300	666/706	610/790	466/506	4715	20-100	360 kg	990 kg

JesBelt S 900 [up to 250 m ³ /h]												Weight open	Weight closed
C	B	J	K	H*	G	L	U*	M*	N*	P	X**		
2800	900	1540	600	2530/2550	310	500	866/906	700/880	566/606	3415	20-100	355 kg	1040 kg
3400	900	1940	700	3130/3150	310	500	866/906	700/880	566/606	4015	20-100	370 kg	1090 kg
4200	900	2740	700	3930/3950	310	500	866/906	700/880	566/606	4815	20-100	390 kg	1160 kg

JesBelt S 1100 [up to 400 m ³ /h]												Weight open	Weight closed
C	B	J	K	H*	G	L	U*	M*	N*	P	X**		
3400	1100	1940	700	3030/3050	410	700	1066/1106	700/880	566/606	4015	20-100	400 kg	1260 kg
4200	1100	2740	700	3830/3850	410	700	1066/1106	770/880	566/606	4815	20-100	420 kg	1330 kg
4800	1100	3140	700	4230/4250	410	700	1066/1106	770/880	566/606	5215	20-100	440 kg	1400 kg

X = flexible rim or guide rails * Standard length or with manual dust tray / length with emptying conveyor ** Depending on belt type

JesBelt® D

Compact simplicity

Space can be a challenge in any production facility. The JesBelt D with its simple and compact construction provides a great alternative to insert a reliable weigh feeder in positions normally not accessible.

Description of the JesBelt D

The JesBelt consists of a belt suspended in two support profiles. The belt runs on high precision turned end rollers and stainless-steel belt running plates at inlet and discharge. The belt has an adjustable nylon scraper that effectively cleans the belt at the discharge roller, in addition the belt is guided by a height adjustable edge guide.

For multipurpose adjustment possibilities, the weigh feeder is supplied with a height adjustable weigh bridge between the side members and running plates.

The load over the entire width of the belt is metered by a single-point load cell, which in combination with a high signal rate incremental encoder (Tacho) provides high signal accuracy to the weigh amplifier. To ensure optimal weighing accuracy the belt is continuously tensioned through the automatic and gravimetric belt tension.

JesBelt D in general

- Accuracy +/- 1-2% within 20-100% of max. capacity depending on capacity and product characteristics.
- Open version or built into a dust proof cabinet with removeable cover for easy maintenance and belt replacement.

** When the JesBelt D is supplied with housing the belt drive motor is isolated from the potential dusty environment as it is mounted outside the housing.*

- Supplied with flanged inlet and outlet ready for installation.
- Standard: Stainless Steel or mild Steel.
- Incremental encoder (Tacho).
- Adjustable weigh bridge.
- Automatic gravimetric belt tension.
- Scraper on either side of belt.
- Adjustable product guide panels.
- Quick and easy belt change after sliding the weigh bridge out.

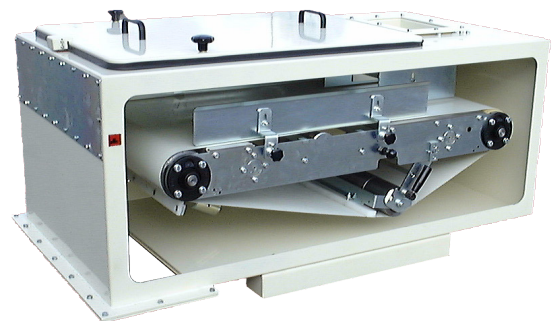

Standard range: JesBelt® D

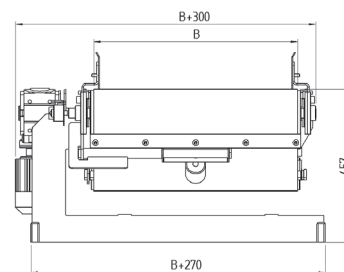
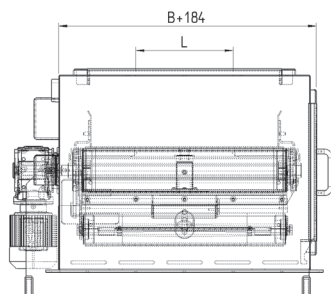
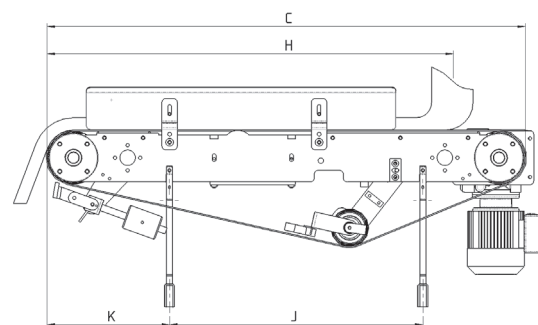
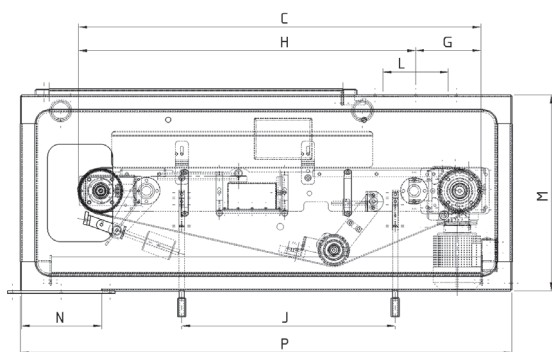

C	B	J	K	H	G	L	M	N	P	Weight open	Weight closed
JesBelt D 310 [up to 40 m³/h]											
1100	380	655	350	1035	200	200	600	245	1506	340 kg	400 kg
JesBelt D 610 [up to 125 m³/h]											
1100	610	655	350	1035	200	200	600	245	1506	420 kg	480 kg

JesBelt® F

Heavy duty - high temperatures - abrasive materials

Sturdy industrial execution, the JesBelt F is well suited for applications with coarse, granular, and dustlike bulk materials with high temperatures and/or abrasive characteristics.

Description of the JesBelt F

Sturdy and simple construction, easy to maintain and service, and with competitive pricing. The simple design makes it possible to adjust the weigh feeder to existing process lines and it is a good alternative to the long conveyor with a belt scale solution.

The JesBelt F is built around the lever principle, it registers the rotational speed on the belt, which requires the inlet to be as small as possible to ensure optimum weighing accuracy. To further secure good material handling, the conveyor belt can be equipped with a flexible rim.

JesBelt F in general

- Accuracy +/- 2% within 20-100% of max. capacity depending on capacity and product characteristics.
- Can handle product temperatures up to 160 °C with short peaks of 200 °C
- Execution in mild steel/ Stainless Steel/ with product wetted parts in stainless steel / or galvanized steel.
- Plough scraper inside the belt.
- Inlet funnel

Options for individual design of JesBelt F

- Dust cover / Open version
- Belt tracking switches
- For some products scraper on outlet can be offered.

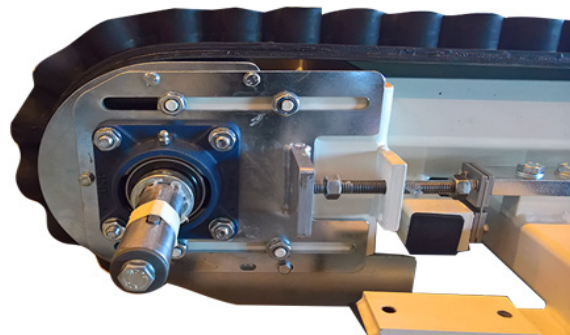

Standard range: JesBelt® F

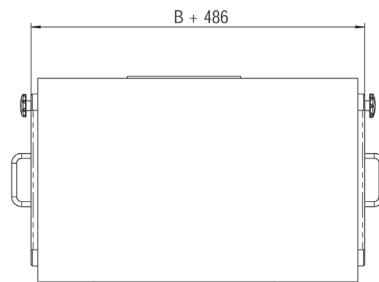
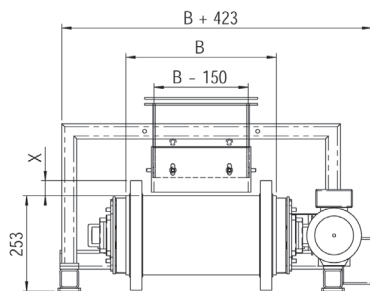
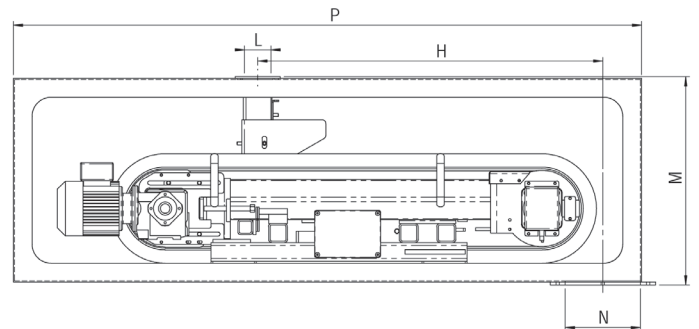
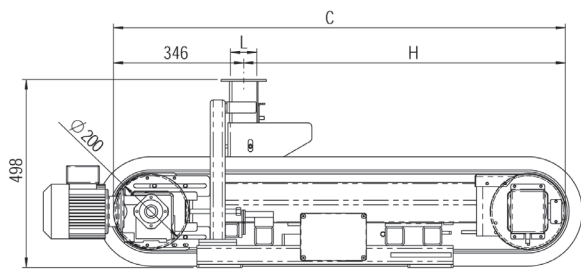

Belt width B	Belt length C	H	L	Up to
400	1200	854	76	20 m ³
500	1600	1254	206	35 m ³
600	2000	1654	206	50 m ³
800	2300	1954	206	90 m ³
1000	2600	2254	276	100 m ³

X: 20, 40, 60 80 mm or through-shaped

Weigh feeder accessories

Flexible rim

To avoid any process fluctuations due to product being stuck between the belt and guide panels, the Jesma weigh feeder is supplied without guide panels but with a flexible rim instead [standard 40 mm, depends on product characteristics].



Scrapers

The belt can be mounted with a spring loaded scraper on the outlet. The scraper ensures that any product sticking to the belt will be removed and thereby not influencing the weighing result.

Depending on the product Jesma can offer the following types of scrapers as standard:

- Standard scraper
- Scraper for sticky products
- Scraper approved for the food-industry
- Roller brush for special applications

If a different type of scraper is required, we will help find a solution.

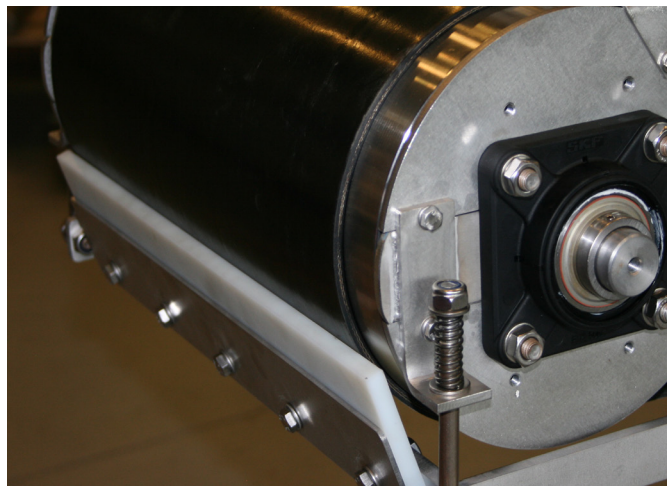

Belt tracking switches

For the continuous monitoring of the belt operation, the weigh feeder can be supplied with a set of belt tracking switches. Depending on the electrical wiring the switches can be connected „Normal Closed“ or „Normal Open“.



Emergency wire stop

To improve the operator safety the weigh feeder can be supplied including emergency stop with wire. The emergency stops are mounted with a wire on both sides providing emergency stop in the full length of the weigh feeder.

Weigh feeder accessories

JesTrack

All weigh feeders can be equipped with a belt tracking system insuring that the belt runs perfectly. The JesTrack consists of an electrical actuator which controls the angle of the turning roller. If the belt starts running to a side, a sensor will be activated.

The sensor will provide a signal to the actuator which then adjusts the angle in the correct direction. JesTrack runs nonstop but has a very low power consumption.

All in all, a fantastic solution for companies appreciating continuous operation.

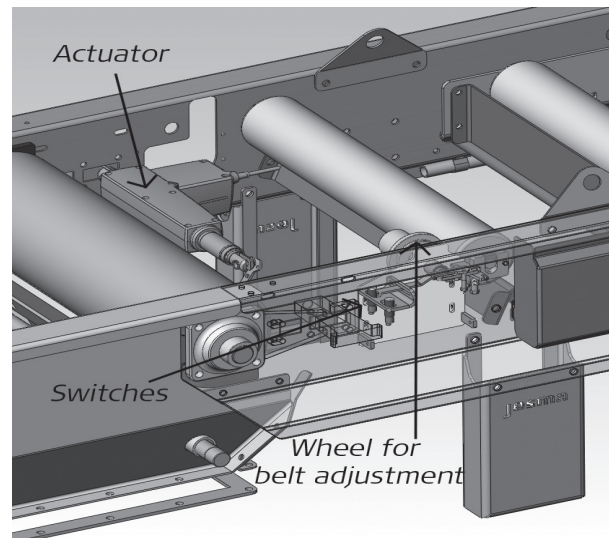

Belt types

The weigh feeders from Jesma can be delivered with different types of belts depending on the material in question.

Belt type	Application	Suitable for low density	Wear resistance	Temperature	Grease/oil resistant	Adhesion
Rubber belt	Strongly abrasive products: Broken glass, sand, gravel, alu. oxid, normal/oily etc.	Low	High	-30° - +110°/200°C	High	High
PVC belt	Adhesive products: sludge, fishmeal, grains with high fat content etc.	Medium	Medium	-30° - +70°/90°C	High	High
PU belt	Dried products: Granulates, meal etc.	High	Medium	-30° - +110°/110°C	High	High
FDA belt	Food approved: Wet products, food etc.	High	Medium	-30° - +110°/130°C	High	High

JesBelt® Z

Inclined transport conveyor

At Jesma Weighing Solutions, we are proud to present the JesBelt Z inclined transport conveyor – our very first creation in this category. We have designed this conveyor system to cater to the specific needs of modern businesses.

Key features and benefits of the JesBelt Z

Unmatched customization

We understand that every business has unique requirements when it comes to material handling. That's why the JesBelt Z inclined transport conveyor is built to be fully customizable. From conveyor length and width to inclination angle and additional features, we work closely with our customers to tailor the system precisely to their needs. Our goal is to provide a solution that seamlessly integrates into your operations, optimizing efficiency and productivity.

Tailored solutions for your space

We understand the value of space optimization in modern facilities. The JesBelt Z is designed to maximize space efficiency, making it an ideal choice for businesses with limited floor space. Its compact design seamlessly integrates into your existing production line, ensuring a smooth material flow without compromising on productivity.

Durability and dependability

Built to withstand the rigors of industrial environments, the JesBelt Z is constructed using high-quality materials. Its robust design ensures exceptional durability and long-lasting performance, even in demanding conditions. By minimizing maintenance requirements and maximizing uptime, this conveyor system offers you peace of mind and operational efficiency.

Adjustable speed control

The inclined transport conveyor offers adjustable speed control, allowing you to optimize the material transfer process according to your specific requirements. Whether you need to increase throughput or handle delicate materials with care, the ability to control the conveyor speed ensures efficient and precise operation.

Dust containment and air filtration

In applications where materials may generate dust or require a controlled environment, specialized inclined transport conveyors may incorporate dust containment measures and air filtration systems. These features help maintain a clean and safe working environment while preventing the dispersion of particles into the surrounding area.

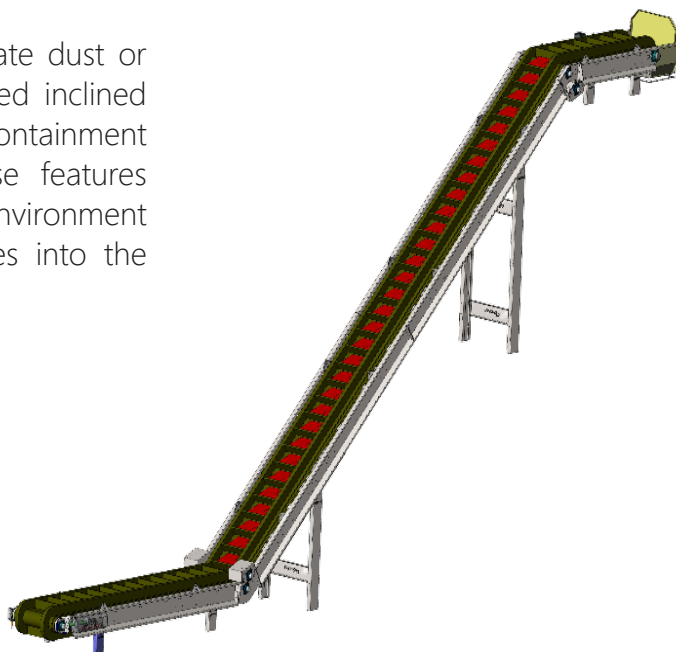

Standard range: JesBelt® Z and JesBelt® V

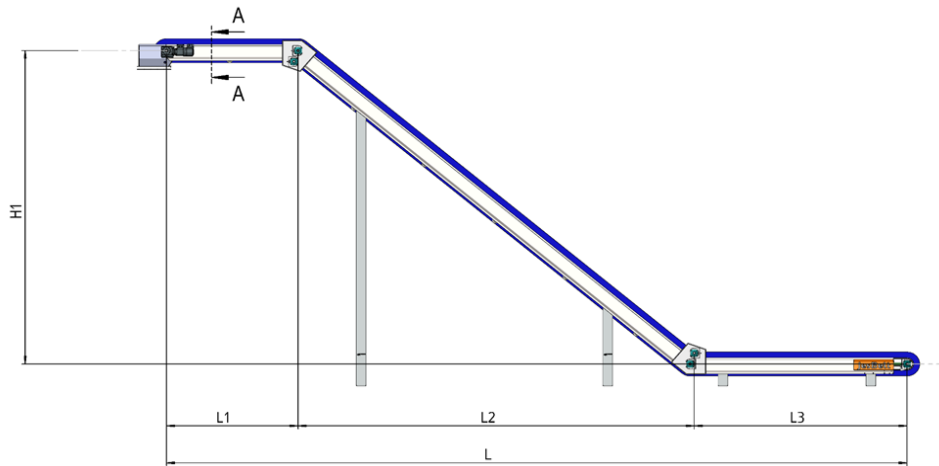

JesBelt Z 700		[up to 43 m ³ /hr]				
B [mm]	B1 [mm]	H [mm]	L1 [mm]	L2 [mm]	L3 [mm]	L [mm]
700	400	5000	2000	6000	2000	10000
700	400	4000	2000	4800	2000	8800
700	400	3000	2000	3600	2000	7600
700	400	2000	2000	2400	2000	6400

JesBelt Z 1000		[up to 90 m ³ /hr]				
B [mm]	B1 [mm]	H [mm]	L1 [mm]	L2 [mm]	L3 [mm]	L [mm]
1000	700	5000	2000	6000	2000	10000
1000	700	4000	2000	4800	2000	8800
1000	700	3000	2000	3600	2000	7600
1000	700	2000	2000	2400	2000	6400

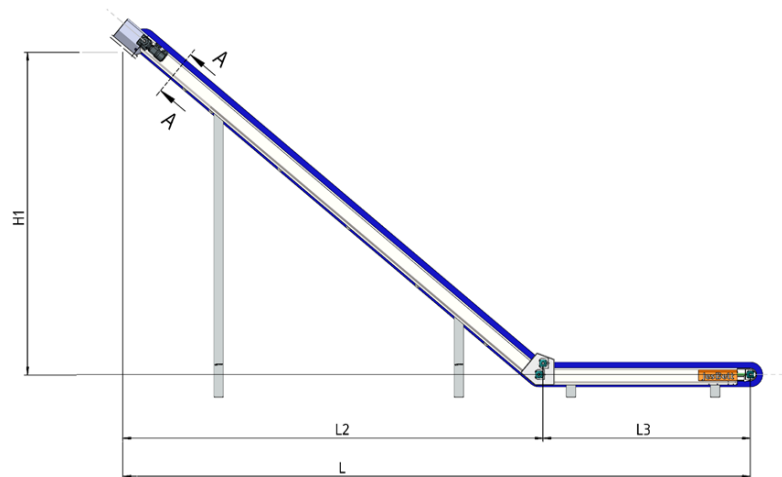

JesBelt V 700		[up to 43 m ³ /hr]			
B [mm]	B1 [mm]	H [mm]	L2 [mm]	L3 [mm]	L [mm]
700	400	5000	6000	2000	8000
700	400	4000	4800	2000	6800
700	400	3000	3600	2000	5600
700	400	2000	2400	2000	4400

JesBelt V 1000		[up to 90 m ³ /hr]			
B [mm]	B1 [mm]	H [mm]	L2 [mm]	L3 [mm]	L [mm]
1000	400	5000	6000	2000	8000
1000	400	4000	4800	2000	6800
1000	400	3000	3600	2000	5600
1000	400	2000	2400	2000	4400



Jesma Poland
Ul. Firmowa 18
PL-62-023 Robakowo
(+48) 722 011 022
mtr@jesma.com

Jesma HQ
Helsingørvej 18
DK-7100 Vejle
+45 75 72 11 00
Jesma@jesma.dk

Jesma/SEG
Forettgatan 33
SE-254 67 Helsingborg
+46 87 64 74 00
info-seg@jesmagroup.com

 Part of Jesma Group

www.jesma.com